

# iFlight Borg F7 Mini FC Wiring diagram

## Parameters:

FC Specifications  
 Input voltage: 4-6S, Support LHV battery  
 Dimensions: 27\*55.6mm\*11  
 Mount standard: 20\*20\*4  
 Weight: 6.8g\*1  
 MCU: AT32F722RE16  
 Gyro: ICX424268  
 Baro: SP404-005  
 OSD: AT7456E (LGA)  
 BlackBox: 52MB  
 Motor outputs: 4  
 QIC: Yes  
 BEC: 5V 2.5A, 12V 2A (12V with VTX switch)  
 LED Strip: Supported  
 Buzzer: Yes  
 VTX protocol: Support DJI MSP/SmartAudio/RCTransp/HDZero  
 UARTS: 6  
 Uart: 6\*UART (UART1, UART2, UART3, UART4, UART5, UART6)  
 UART1: VTX HD / Analog  
 UART2: Receiver  
 UART3: GPS or other sensors that require a serial port  
 UART4: GPS  
 UART5: GPS or other sensors that require a serial port  
 UART6: ESC Telemet  
 VTX\_ON/OFF Mode Command:  
 resource PINIO 1 C0  
 set gpio\_config = 1,1,1,1  
 set pinio\_box = 40,41,255,255  
 set box\_user\_1\_name = VTX\_ON/OFF  
 aux 0 40 8 900 2100 0 0  
 save

Firmware:  
 Betaflight: #FLIGHT\_BUTZ\_F722  
 NAV: #FLIGHT\_BUTZ\_F722

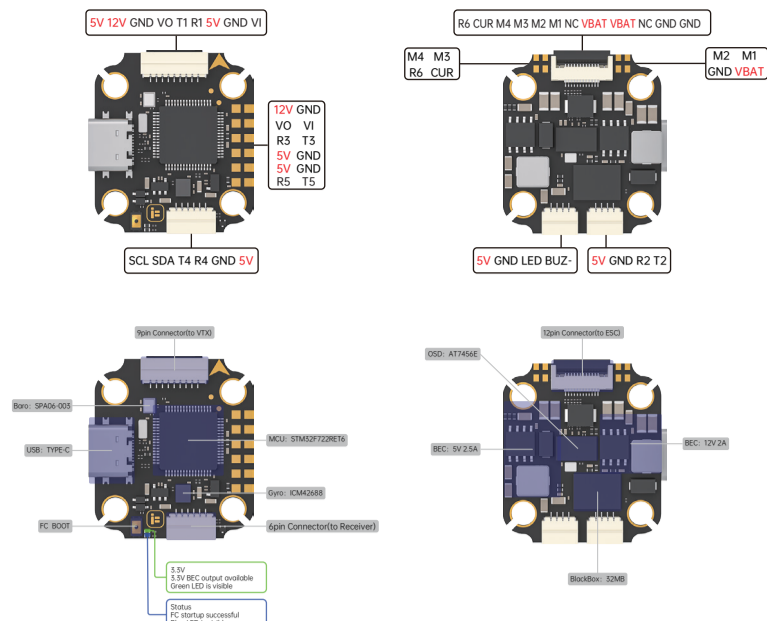

## DJI Digital Transmitters: SUBS Protocol

Firmware Target: #FLIGHT\_BUTZ\_F722

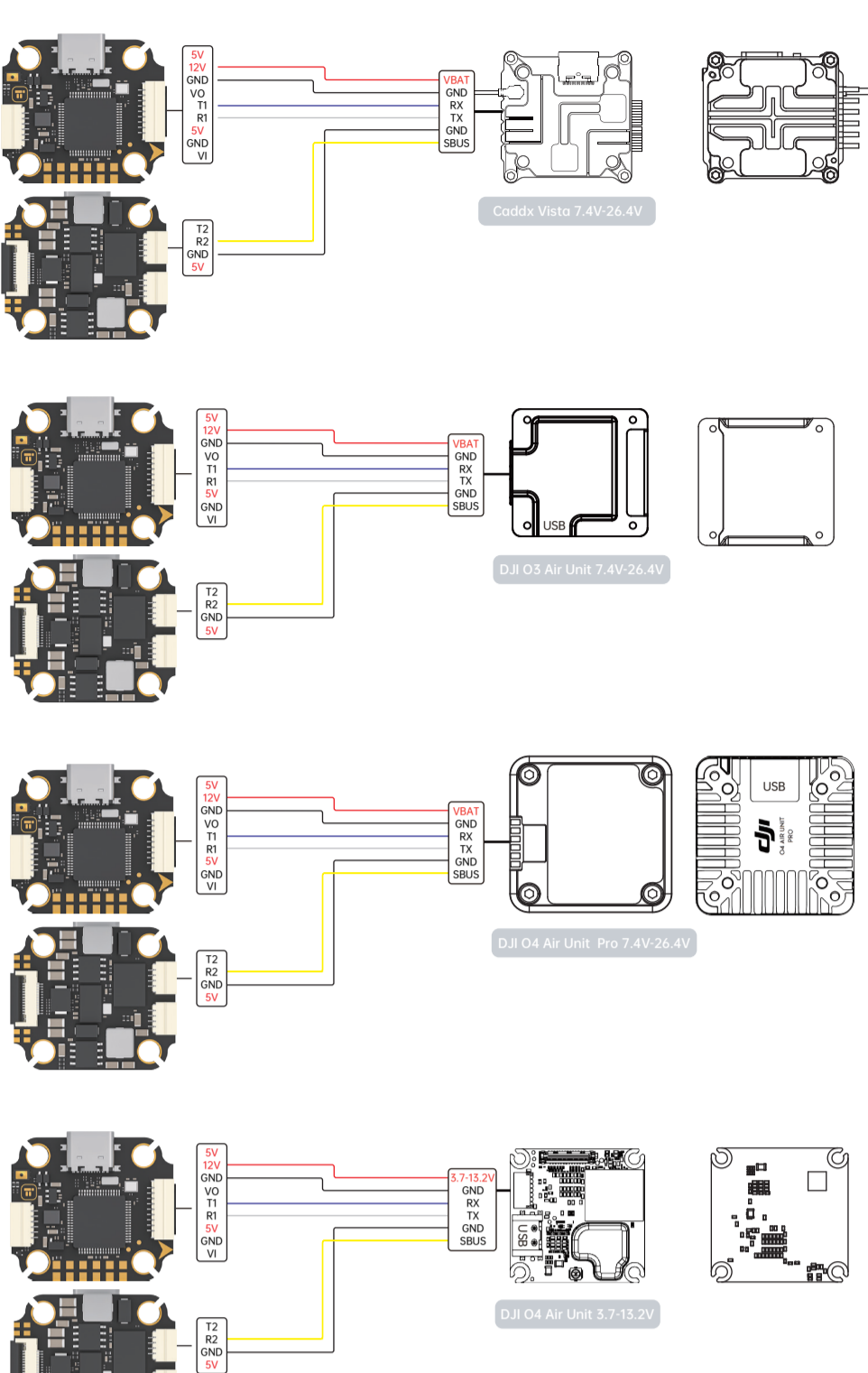

Receiver	Mode	Protocol	Port	Receiver Mode
UBLOX	UART	UBLOX	UART1	UART
UBLOX	UART	UBLOX	UART2	UART
UBLOX	UART	UBLOX	UART3	UART
UBLOX	UART	UBLOX	UART4	UART
UBLOX	UART	UBLOX	UART5	UART
UBLOX	UART	UBLOX	UART6	UART

Receiver Mode: Serial (via UART) Receiver Mode

The UART for the receiver must be set to Serial Rx (in the Ports tab)  
 Select the correct data format from the drop-down, below:

CRSF Serial Receiver Provider

Telemetry:  TELEMETRY Telemetry output

- To enable the air unit OSD under Betaflight 4.4 version, you need to select VTX (MSP+Displayport) in the peripheral port where the air unit is connected to the port interface.
- note: DJI FPV Remote Controller 2 is for DJI O3 Air Unit DJI FPV Remote Controller is for DJI Air Unit and Vista
- Please check your protocols, otherwise your DJI Radio won't input signals!  
 DJI Goggle protocol and Betaflight protocol has to match!  
 For lower signal latency use the SBus BAUD\_FAST protocol option on both ends.
- For Betaflight Copy Paste"set sbus baud fast-on" into your Betaflight Configurator CLI then hit enter.  
 Use "save" and hit enter to save the changes.  
 Default: sbus\_baud\_fast-off, Goggle protocol set to NORMAL

## Others Receivers(TBS/ELRS): CRSF Protocol

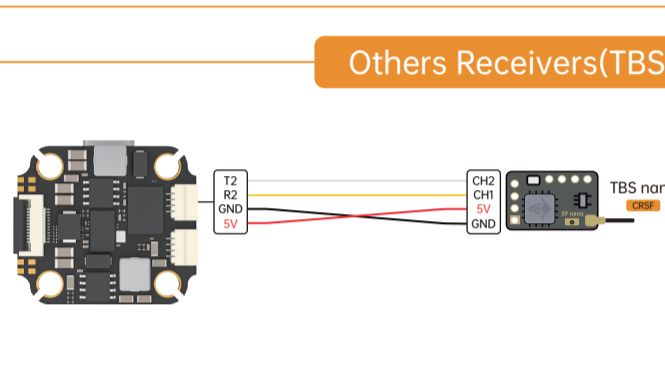

Receiver	Mode	Protocol	Port	Receiver Mode
UBLOX	UART	UBLOX	UART1	UART
UBLOX	UART	UBLOX	UART2	UART
UBLOX	UART	UBLOX	UART3	UART
UBLOX	UART	UBLOX	UART4	UART
UBLOX	UART	UBLOX	UART5	UART
UBLOX	UART	UBLOX	UART6	UART

Receiver Mode: Serial (via UART) Receiver Mode

The UART for the receiver must be set to Serial Rx (in the Ports tab)  
 Select the correct data format from the drop-down, below:

CRSF Serial Receiver Provider

Telemetry:  TELEMETRY Telemetry output

## LED/BUZZER

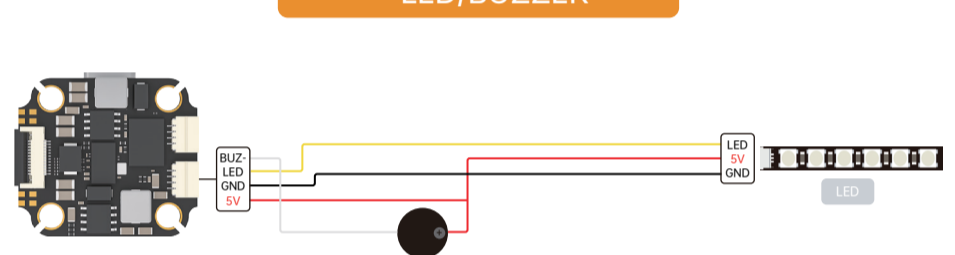

## ESC

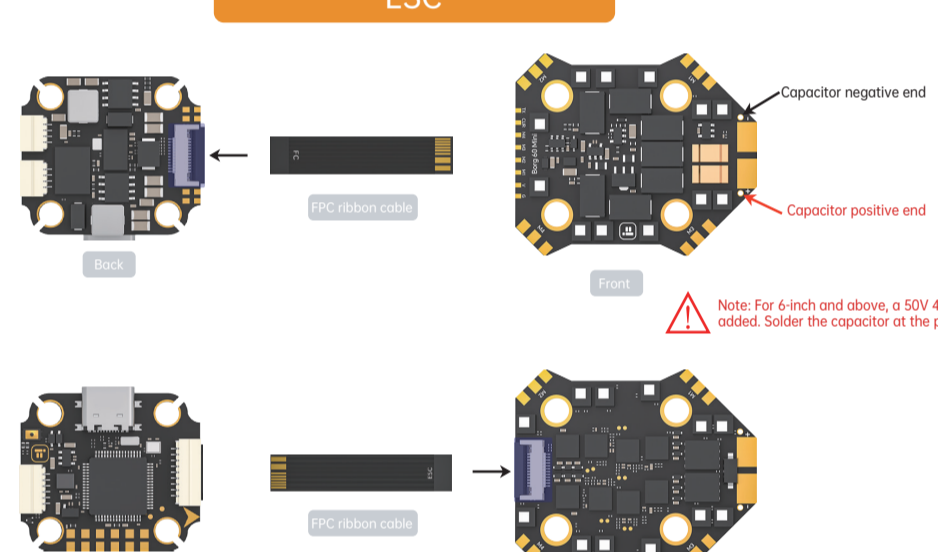

Note: For 6-inch and above, a 50V 470uF capacitor needs to be added. Solder the capacitor at the position indicated by the arrow.

Note: If using ESCs from other brands, please ensure the wiring is connected correctly. 5-inch models do not require an external capacitor to fly, while 6-inch or larger models need to add a 50V 470uF capacitor.

## VTX/CAM

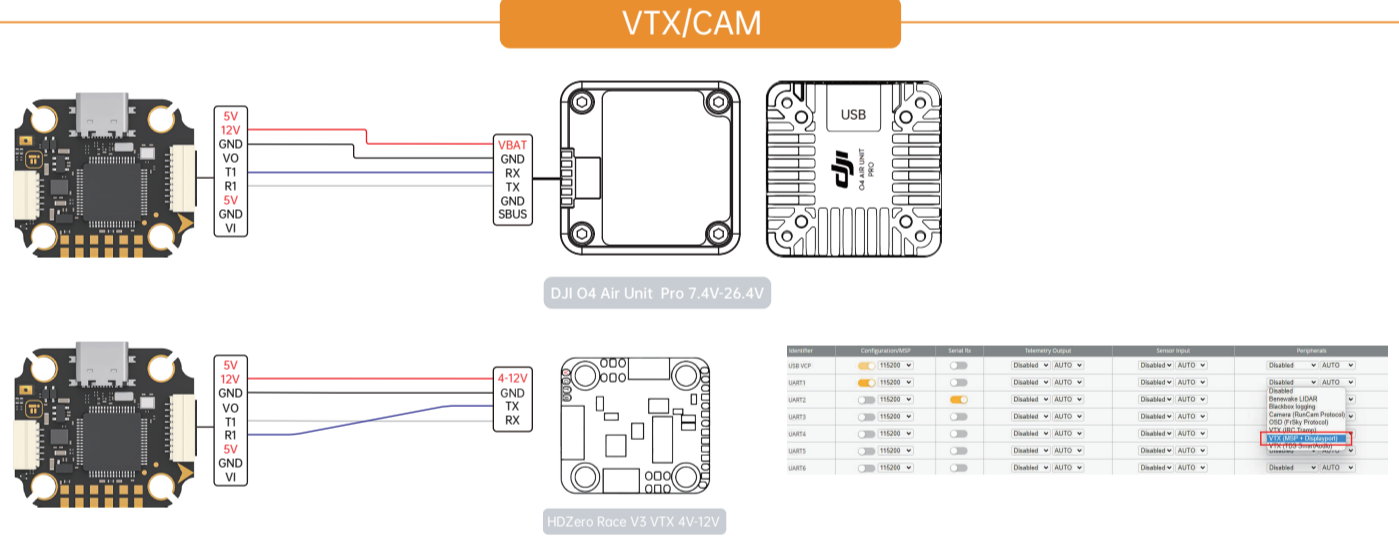

Receiver	Mode	Protocol	Port	Receiver Mode
UBLOX	UART	UBLOX	UART1	UART
UBLOX	UART	UBLOX	UART2	UART
UBLOX	UART	UBLOX	UART3	UART
UBLOX	UART	UBLOX	UART4	UART
UBLOX	UART	UBLOX	UART5	UART
UBLOX	UART	UBLOX	UART6	UART

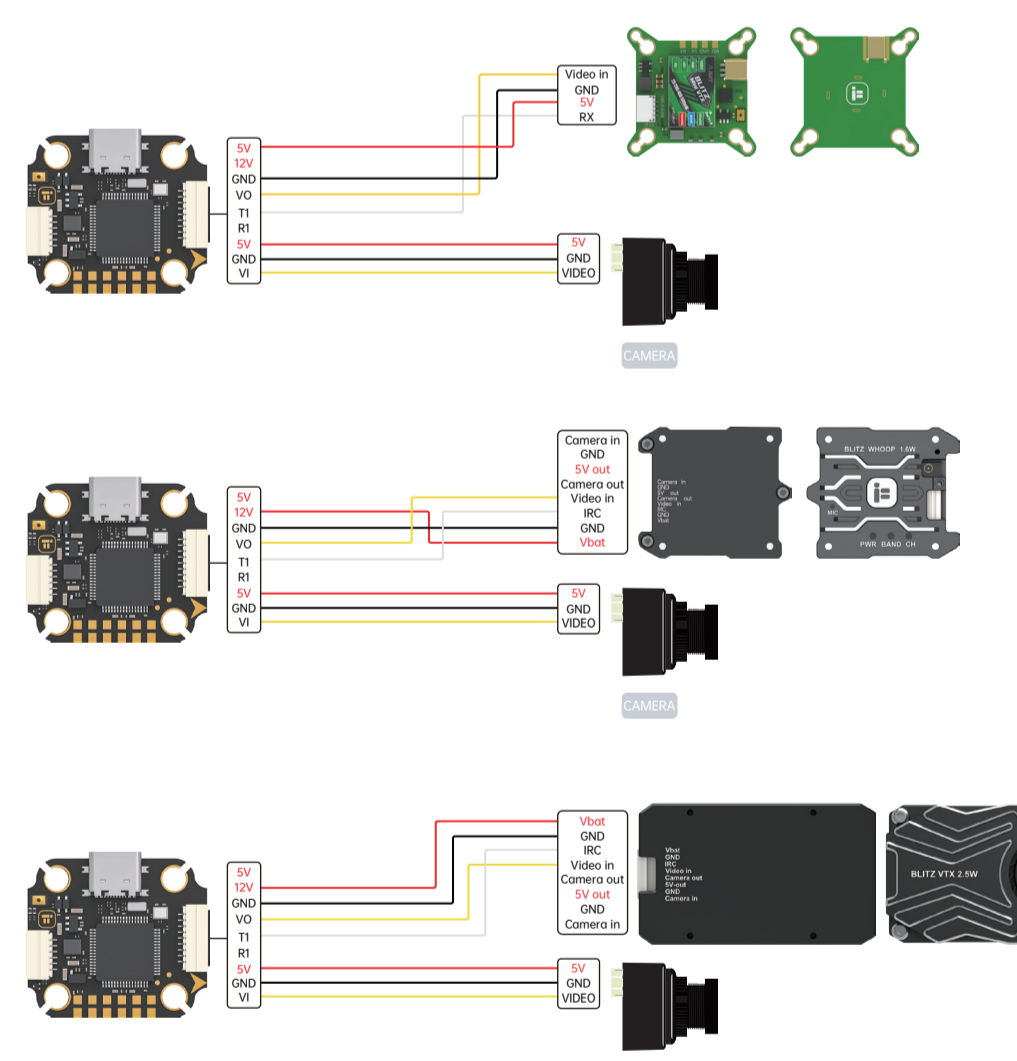

Identifier	Configuration/MSP	Serial Rx	Telemetry Output	Sensor Input	Peripherals
USB VCP	<input checked="" type="checkbox"/> 115200	<input type="checkbox"/>	Disabled   AUTO	Disabled   AUTO	Disabled   AUTO
UART1	<input type="checkbox"/> 115200	<input type="checkbox"/>	Disabled   AUTO	Disabled   AUTO	Disabled   AUTO
UART2	<input type="checkbox"/> 115200	<input checked="" type="checkbox"/>	Disabled   AUTO	Disabled   AUTO	Disabled   AUTO
UART3	<input type="checkbox"/> 115200	<input type="checkbox"/>	Disabled   AUTO	Disabled   AUTO	Disabled   AUTO
UART4	<input type="checkbox"/> 115200	<input type="checkbox"/>	Disabled   AUTO	Disabled   AUTO	Disabled   AUTO
UART5	<input type="checkbox"/> 115200	<input type="checkbox"/>	Disabled   AUTO	Disabled   AUTO	Disabled   AUTO
UART6	<input type="checkbox"/> 115200	<input type="checkbox"/>	Disabled   AUTO	Disabled   AUTO	Disabled   AUTO

VTX\_ON/OFF Mode On

VTX\_ON/OFF Mode Off

To control VTX on/off, please drag the range to 1600-2000. If the icon is yellow, it is on, and if it is gray, it is off.

Reflooding firmware or restoring the default factory settings requires manually entering the following commands in Betaflight CLI to re-enable VTX switch control:

```
resource PINIO 1 C0
set gpio_config = 1,1,1,1
set pinio_box = 40,41,255,255
set box_user_1_name = VTX_ON/OFF
aux 0 40 8 900 2100 0 0
save
```

## GPS

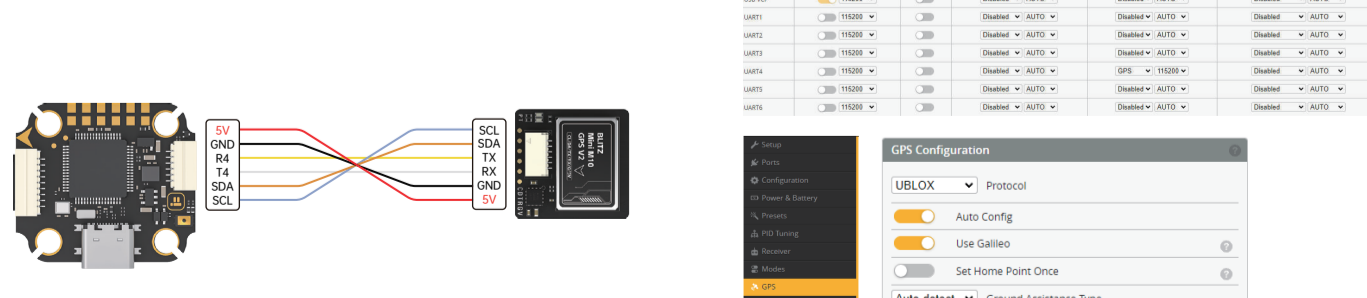

SDA/SCL pads can not be remapped to UARTS

## Dimensions/Mounting pattern

